

SIEMENS

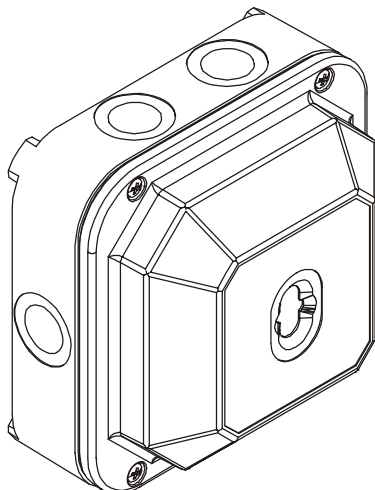

FDF241-9

Flame detector

Technical Manual

Table of contents

1	About this document.....	5
1.1	Applicable documents.....	7
1.2	Download center.....	8
1.3	Technical terms.....	8
1.4	History of changes.....	9
2	Safety.....	11
2.1	Safety instructions.....	11
2.2	Safety regulations for the method of operation.....	13
2.3	Standards and directives complied with.....	15
2.4	Release Notes.....	15
3	Structure and function.....	16
3.1	Overview.....	16
3.1.1	Characteristics of the flame detector.....	17
3.1.2	Details for ordering.....	17
3.2	Setup.....	18
3.3	Function.....	22
3.3.1	Line separator.....	23
3.3.2	Selftest.....	23
3.3.3	Messages to the control panel.....	24
3.4	Accessories.....	25
3.4.1	Mounting bracket MV1.....	25
3.4.2	Ball and socket joint MWV1.....	25
3.4.3	Rain hood DFZ1190.....	25
3.4.4	Rain hood FDFZ241.....	26
3.4.5	LE3 Test lamp.....	26
3.4.6	M20 x 1.5 metal cable gland.....	26
3.4.7	Micro terminal DBZ1190-AA.....	27
3.4.8	Connection terminal DBZ1190-AB.....	27
4	Planning.....	28
4.1	Establish flame detector arrangement.....	28
4.1.1	Line of sight.....	29
4.1.2	Arrangement of several flame detectors.....	30
4.1.3	Deceptive phenomena.....	31
4.1.4	Examples of application.....	31
4.2	Defining the place of installation.....	32
4.2.1	Calculate detection distance.....	33
4.2.2	Calculate mounting height.....	35
4.3	Mask deceptive phenomena.....	36
4.4	Determine parameter set.....	37
4.4.1	Parameter sets for FDF241-9.....	38

5	Mounting / Installation	40
5.1	Switch flame detector over to collective operation	40
5.2	Fit base for flame detector	42
5.3	Electrical connection	44
5.3.1	Connection to an addressed detector line.....	45
5.3.1.1	Use of unshielded cables	45
5.3.1.2	Use of shielded cables	46
5.3.2	Connection to a collective detector line.....	47
5.3.2.1	Use of unshielded cables	47
5.3.2.2	Use of shielded cables	48
6	Commissioning	50
6.1	Commissioning an addressed detector line	50
6.1.1	Install flame detector on base for flame detector.....	50
6.1.2	Set parameter set	52
6.1.3	Run performance check.....	52
6.2	Commissioning on a collective detector line	53
6.2.1	Set parameter set	53
6.2.2	Install flame detector on base for flame detector.....	54
6.2.3	Run performance check.....	55
7	Maintenance / Repair.....	56
7.1	Performance check.....	56
7.2	Cleaning	57
7.3	Repair	58
8	Specifications.....	59
8.1	Technical data	59
8.2	Dimensions.....	62
8.3	Environmental compatibility and disposal	64
Index	65

1 About this document



- Specialist electrical engineering knowledge is required for installation.
 - Only an expert is permitted to carry out installation work.
- Incorrect installation can take safety devices out of operation unbeknown to a layperson.

Goal and purpose

This document contains all necessary information on the flame detector FDF241-9. Following the instructions consistently will ensure that the product can be used safely and without any problems.

Intended use

The manual call point FDF241-9 must only be used in one of the following fire detection systems:

- FS20
- FS720
- FC360

Target groups

The information in this document is intended for the following target groups:

Target group	Activity	Qualification
Product Manager	<ul style="list-style-type: none"> Is responsible for information passing between the manufacturer and regional company. Coordinates the flow of information between the individual groups of people involved in a project. 	<ul style="list-style-type: none"> Has obtained suitable specialist training for the function and for the products. Has attended the training courses for Product Managers.
Project Manager	<ul style="list-style-type: none"> Coordinates the deployment of all persons and resources involved in the project according to schedule. Provides the information required to run the project. 	<ul style="list-style-type: none"> Has obtained suitable specialist training for the function and for the products. Has attended the training courses for Project Managers.
Project engineer	<ul style="list-style-type: none"> Sets parameters for product depending on specific national and/or customer requirements. Checks operability and approves the product for commissioning at the place of installation. Is responsible for troubleshooting. 	<ul style="list-style-type: none"> Has obtained suitable specialist training for the function and for the products. Has attended the training courses for Product Engineer.
Installation personnel	<ul style="list-style-type: none"> Assembles and installs the product components at the place of installation. Carries out a performance check following installation. 	<ul style="list-style-type: none"> Has received specialist training in the area of building installation technology or electrical installations.
Commissioning personnel	<ul style="list-style-type: none"> Configure the product at the place of installation according to customer-specific requirements. Check the product operability and release the product for use by the operator. Searches for and corrects malfunctions. 	<ul style="list-style-type: none"> Has obtained suitable specialist training for the function and for the products. Has attended the training courses for commissioning personnel.
Maintenance personnel	<ul style="list-style-type: none"> Carries out all maintenance work. Checks that the products are in perfect working order. Searches for and corrects malfunctions. 	<ul style="list-style-type: none"> Has obtained suitable specialist training for the function and for the products.

Document identification

The document ID is structured as follows:

ID code	Examples
ID_ModificationIndex_Language_COUNTRY -- = multilingual or international	A6V10215123_a_de_DE A6V10215123_a_en_-- A6V10315123_a_--_--

Date format

The date format in the document corresponds to the recommendation of international standard ISO 8601 (format YYYY-MM-DD).

Conventions for text marking

Markups

Special markups are shown in this document as follows:

▷	Requirement for a behavior instruction
1. 2.	Behavior instruction with at least two operation sequences
–	Version, option, or detailed information for a behavior instruction
⇒	Intermediate result of a behavior instruction
⇨	End result of a behavior instruction
•	Numbered lists and behavior instructions with an operation sequence
[→ X]	Reference to a page number
'Text'	Quotation, reproduced identically
<Key>	Identification of keys
>	Relation sign and for identification between steps in a sequence, e.g., 'Menu bar' > 'Help' > 'Help topics'
↑ Text	Identification of a glossary entry

Supplementary information and tips



The 'i' symbol identifies supplementary information and tips for an easier way of working.

1.1 Applicable documents

Document ID	Title
000257	Operating instructions Test lamp LE3
001508	Guidelines Connection factors, line resistances and capacitances for fire detection systems collective, AnalogPLUS, interactive, FDnet
007984	Installation Base for flame detector FDFB291
008121	Installation Infrared flame detector FDF241-9
008331	List of compatibility (for 'Sinteso™' product line)
009977	Acceptance test fire (Guideline) Detector system FD20
A6V10229261	List of compatibility (for 'Cerberus™ PRO' product line)
A6V10299652	Commissioning Flame detector FDF241-9
A6V10882301	List of compatibility (for 'FC360' product line)
A6V10882455	Installation Rain hood FDFZ241

1.2 Download center

You can download various types of documents, such as data sheets, installation instructions, and license texts via the following Internet address:

<http://siemens.com/bt/download>

- Enter the document ID in the 'Find by keyword' input box.



You will also find information about search variants and links to mobile applications (apps) for various systems on the home page.

1.3 Technical terms

Term	Explanation
ABS	Acrylonitrile-butadiene-styrene (plastic)
ASA	Advanced Signal Analysis
DA	Detection algorithms
FDnet/C-NET	Addressed detector line
LED	Light-emitting diode
PC	Polycarbonate (plastic)
S-LINE	Fire detector for sophisticated applications

1.4 History of changes

The reference document's version applies to all languages into which the reference document is translated.



The first edition of a language version or a country variant may, for example, be version 'd' instead of 'a' if the reference document is already this version.

The table below shows this document's revision history:

Modification index	Edition date	Brief description
k	2016-06-24	<ul style="list-style-type: none"> • Complete revision of the document with adaptation to current editorial guidelines • Flame detector FDF221-9 removed from the document • Rain hood FDFZ241 updated£
j	04.2010	Reference documents adapted, revision history redefined and standardized
i	10.2009	Editorial adjustments made
h	09.2009	Revision of content and layout
g	09.2007	Standard EN 54-17 and LPCB approval added; line separator parameters added; air humidity details changed
f	08.2006	Shielding in connection diagram supplemented; collective and FDnet performance checks revised; technical data revised
e	05.2005	9.1 Technical data, system compatibility
d	02.2005	FDF241-9: Parameter sets 4 + 5 extended
c	01.2005	9.2 Response time supplement
b	12.2003	Layout adjustment
a	12.2003	First edition



The language versions and country variants produced by a local company have the same modification index as the corresponding reference document. They are not however included in the table below.

The table below shows the published language versions and country variants with the corresponding modification index:

Modification index	en_--	de_--	fr_--	it_--	es_--
k	X	X	X	X	X
j	X	X	X	X	X
i	–	X	–	–	–
h	X	X	–	–	–
g	X	X	–	–	–
f	X	X	–	–	–
e	X	X	–	–	–
d	X	X	–	–	–
c	X	X	–	–	–
b	X	X	X	X	X
a	X	X	X	X	X

X = published

– = no publication with this modification index

2 Safety

2.1 Safety instructions

The safety notices must be observed in order to protect people and property.

The safety notices in this document contain the following elements:

- Symbol for danger
- Signal word
- Nature and origin of the danger
- Consequences if the danger occurs
- Measures or prohibitions for danger avoidance

Symbol for danger



This is the symbol for danger. It warns of **risks of injury**.
Follow all measures identified by this symbol to avoid injury or death.

Additional danger symbols

These symbols indicate general dangers, the type of danger or possible consequences, measures and prohibitions, examples of which are shown in the following table:



General danger



Explosive atmosphere



Voltage/electric shock



Laser light



Battery



Heat

Signal word

The signal word classifies the danger as defined in the following table:

Signal word	Danger level
DANGER	DANGER identifies a dangerous situation, which will result directly in death or serious injury if you do not avoid this situation.
WARNING	WARNING identifies a dangerous situation, which may result in death or serious injury if you do not avoid this situation.
CAUTION	CAUTION identifies a dangerous situation, which could result in slight to moderately serious injury if you do not avoid this situation.
<i>NOTICE</i>	<i>NOTICE</i> identifies possible damage to property that may result from non-observance.

How risk of injury is presented

Information about the risk of injury is shown as follows:

	<p>⚠ WARNING</p>
	<p>Nature and origin of the danger Consequences if the danger occurs</p> <ul style="list-style-type: none"> • Measures / prohibitions for danger avoidance

How possible damage to property is presented

Information about possible damage to property is shown as follows:



	<p><i>NOTICE</i></p>
	<p>Nature and origin of the danger Consequences if the danger occurs</p> <ul style="list-style-type: none"> • Measures / prohibitions for danger avoidance

2.2 Safety regulations for the method of operation

National standards, regulations and legislation

Siemens products are developed and produced in compliance with the relevant European and international safety standards. Should additional national or local safety standards or legislation concerning the planning, mounting, installation, operation or disposal of the product apply at the place of operation, then these must also be taken into account together with the safety regulations in the product documentation.

Electrical installations

	<p>⚠ WARNING</p> <p>Electrical voltage Electric shock</p> <ul style="list-style-type: none"> • Work on electrical installations may only be carried out by qualified electricians or by instructed persons working under the guidance and supervision of a qualified electrician, in accordance with the electrotechnical regulations.
<ul style="list-style-type: none"> • Wherever possible disconnect products from the power supply when carrying out commissioning, maintenance or repair work on them. • Lock volt-free areas to prevent them being switched back on again by mistake. • Label the connection terminals with external voltage using a 'DANGER External voltage' sign. • Route mains connections to products separately and fuse them with their own, clearly marked fuse. • Fit an easily accessible disconnecting device in accordance with IEC 60950-1 outside the installation. • Produce earthing as stated in local safety regulations. 	
	<p>⚠ CAUTION</p> <p>Noncompliance with the following safety regulations Risk of injury to persons and damage to property</p> <ul style="list-style-type: none"> • Compliance with the following regulations is required.
	<ul style="list-style-type: none"> • Specialist electrical engineering knowledge is required for installation. • Only an expert is permitted to carry out installation work. <p>Incorrect installation can take safety devices out of operation unbeknown to a layperson.</p>

Mounting, installation, commissioning and maintenance

- If you require tools such as a ladder, these must be safe and must be intended for the work in hand.
- When starting the fire control panel ensure that unstable conditions cannot arise.
- Ensure that all points listed in the 'Testing the product operability' section below are observed.
- You may only set controls to normal function when the product operability has been completely tested and the system has been handed over to the customer.

Testing the product operability

- Prevent the remote transmission from triggering erroneously.
- If testing building installations or activating devices from third-party companies, you must collaborate with the people appointed.
- The activation of fire control installations for test purposes must not cause injury to anyone or damage to the building installations. The following instructions must be observed:
 - Use the correct potential for activation; this is generally the potential of the building installation.
 - Only check controls up to the interface (relay with blocking option).
 - Make sure that only the controls to be tested are activated.
- Inform people before testing the alarm devices and allow for possible panic responses.
- Inform people about any noise or mist which may be produced.
- Before testing the remote transmission, inform the corresponding alarm and fault signal receiving stations.

Modifications to the system design and the products

Modifications to the system and to individual products may lead to faults, malfunctioning and safety risks. Written confirmation must be obtained from Siemens and the corresponding safety bodies for modifications or additions.

Modules and spare parts

- Components and spare parts must comply with the technical specifications defined by Siemens. Only use products specified or recommended by Siemens.
- Only use fuses with the specified fuse characteristics.
- Wrong battery types and improper battery changing lead to a risk of explosion. Only use the same battery type or an equivalent battery type recommended by Siemens.
- Batteries must be disposed of in an environmentally friendly manner. Observe national guidelines and regulations.

Disregard of the safety regulations

Before they are delivered, Siemens products are tested to ensure they function correctly when used properly. Siemens disclaims all liability for damage or injuries caused by the incorrect application of the instructions or the disregard of danger warnings contained in the documentation. This applies in particular to the following damage:



- Personal injuries or damage to property caused by improper use and incorrect application
- Personal injuries or damage to property caused by disregarding safety instructions in the documentation or on the product
- Personal injury or damage to property caused by poor maintenance or lack of maintenance

2.3 Standards and directives complied with

A list of the standards and directives complied with is available from your Siemens contact.

2.4 Release Notes

Limitations to the configuration or use of devices in a fire detection installation with a particular firmware version are possible.

	<p>⚠ WARNING</p> <p>Limited or non-existent fire detection Personal injury and damage to property in the event of a fire.</p> <ul style="list-style-type: none"> • Read the 'Release Notes' before you plan and/or configure a fire detection installation. • Read the 'Release Notes' before you carry out a firmware update to a fire detection installation.
	<p>NOTICE</p> <p>Incorrect planning and/or configuration Important standards and specifications are not satisfied. Fire detection installation is not accepted for commissioning. Additional expense resulting from necessary new planning and/or configuration.</p> <ul style="list-style-type: none"> • Read the 'Release Notes' before you plan and/or configure a fire detection installation. • Read the 'Release Notes' before you carry out a firmware update to a fire detection installation.

3 Structure and function

3.1 Overview

The flame detector measures infrared radiation and can therefore detect organic material fires with and without smoke.

The table below shows what types of fire the flame detector can and cannot detect.

Detection	No detection
Liquid fires without smoke	-
Gas fires without smoke	-
Open organic material fires with smoke, for example fires of: <ul style="list-style-type: none"> • Wood • Synthetic material • Gas • Oil-based products 	Inorganic materials, such as: <ul style="list-style-type: none"> • Hydrogen • Phosphorus • Sodium • Magnesium • Sulfur

However if inorganic materials are burning in a fire with organic materials, e.g. packaging material, the flame detector can detect the fire.

The flame detector can be operated on both an FDnet/C-NET detector line and a collective detector line.

A mounting bracket and ball and socket joint are available to aid flame detector mounting at a particular angle. Two rain hoods are available to protect against rain. More information can be found in the 'Accessories' chapter.

See also

 [Accessories \[→ 25\]](#)

3.1.1 Characteristics of the flame detector

Functions

- Microprocessor-controlled signal processing
- Selective evaluation of flickering sequence
- False alarm immunity
- Evaluation of different wave lengths
- Selftest

Sensory

- Two pyroelectric sensors and one silicon photo diode

Compatibility

FDnet/C-NET and collective detector lines (for details, see 'List of compatibility')

Typical application

- Indoor and outdoor areas:
 - Industrial storage rooms
 - Hangars
 - Arc welding sites
 - Power plants
 - Print shops
 - Atriums
 - Wood storage
 - Tunnels
 - Transformer rooms
 - Engine test beds

Limitations

- No detection of UV radiation
- No detection of inorganic material fires

3.1.2 Details for ordering

Type	Order number	Designation
FDF241-9	A5Q00003006	Flame detector (S-LINE)
FDFB291	A5Q00003310	Base for flame detector

3.2 Setup

The flame detector consists of the base for flame detector (1) and the flame detector itself (2).

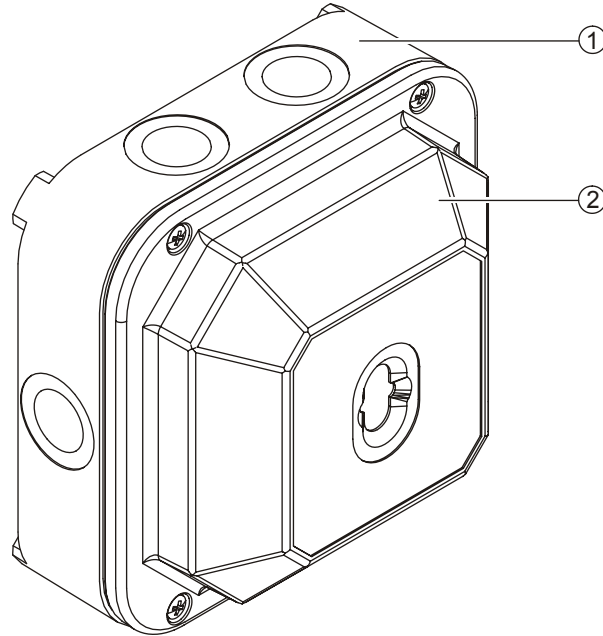

Figure 1: Base for flame detector and flame detector

1 Base for flame detector

2 Flame detector

The components of the flame detector are described in the following sections.

Base for flame detector

The base for flame detector contains the socket strip (2) for connecting to the detector line. The bridging connector (5) simulates the flame detector if not connected to the base. This prevents the detector line from being interrupted.

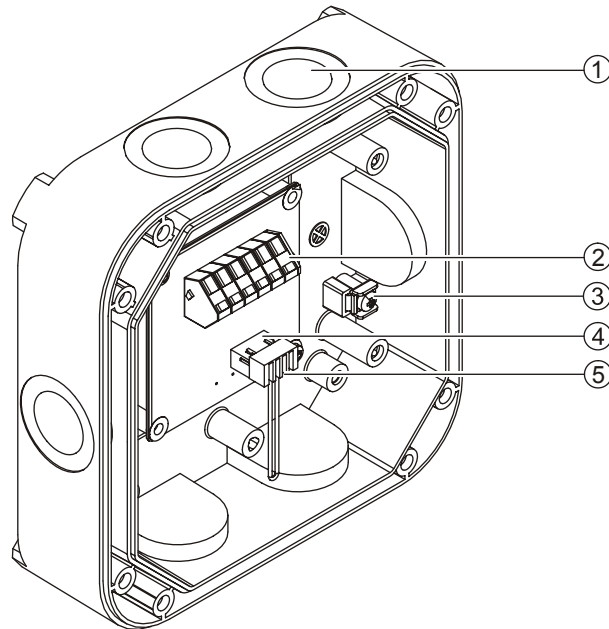

Figure 2: Base for flame detector

- | | |
|--------------------------------|---|
| 1 Six openings for cable entry | 4 Connection for connection cable to flame detector |
| 2 Socket strip | 5 Bridging connector |
| 3 Auxiliary terminal | |

Flame detector

The flame detector contains the electronic components and sensory. Flame detector FDF241-9 has three sensors (A, B, C). The alarm indicator (2) displays an alarm.

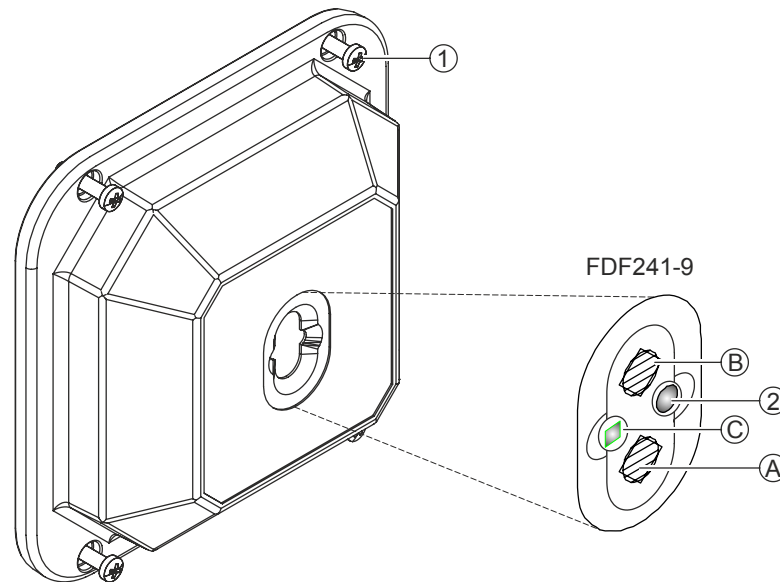

Figure 3: Front of flame detector with enlarged view of sensors

- | | |
|----------------------------|------------|
| 1 Four screws for mounting | A Sensor A |
| 2 Alarm indicator | B Sensor B |
| | C Sensor C |

More information on the sensors can be found in the 'Function [→ 22]' chapter. The connection for the connection cable (2) and the swiveling cover (3) are on the rear of the flame detector. The swiveling cover can be opened to set the parameter set.

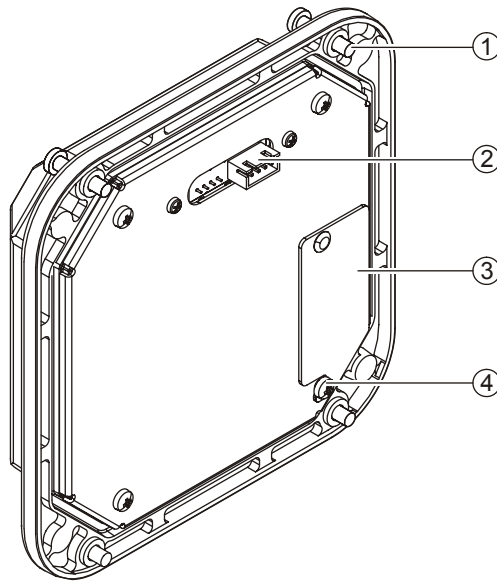

Figure 4: Rear of flame detector

- | | |
|--|------------------------------------|
| 1 Four screws for mounting | 3 Swiveling cover |
| 2 Connection for connection cable to base for flame detector | 4 Screw for fixing swiveling cover |

Connection cable

The electrical connection between the base for flame detector and flame detector is made using the pluggable connection cable.

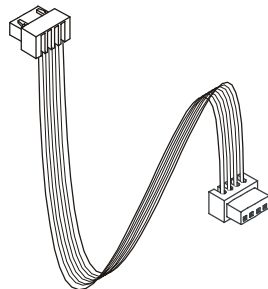

Figure 5: Connection cable

See also

- 📄 Function [→ 22]

3.3 Function

The flame detector detects infrared radiation. The spectrum of organic material fires is very high near the A-channel (see diagram). Full use is made of this for detection as the flame detector measures and evaluates radiation in this spectral range. The description below explains how the sensory of flame detector impacts on detection.

Sensory

Flame detector FDF241-9 has three sensors:

- Pyroelectric sensor A measures the infrared radiation in the characteristic CO₂ spectral range between 4.0 and 4.8 μm (A-channel).
- Pyroelectric sensor B measures the infrared radiation of deceptive phenomena, such as hot objects (3), in the range between 5.1 and 6.0 μm (B-channel).
- Sensor C is a silicon photo diode and measures solar radiation (2) in the range between 0.7 and 1.1 μm (C-channel).

The infrared radiation of the sun, hot objects and organic material fires has different spectra.

Thanks to these characteristics and the three sensors, flame detector FDF241-9 can use **ASA technology** to distinguish between deceptive phenomena and real fires. Flame detector FDF241-9 is suited to use in environments with deceptive phenomena, such as solar radiation or hot motors.

The following diagram shows the spectra of solar radiation, hot objects and organic material fires, in this example of an alcohol fire.

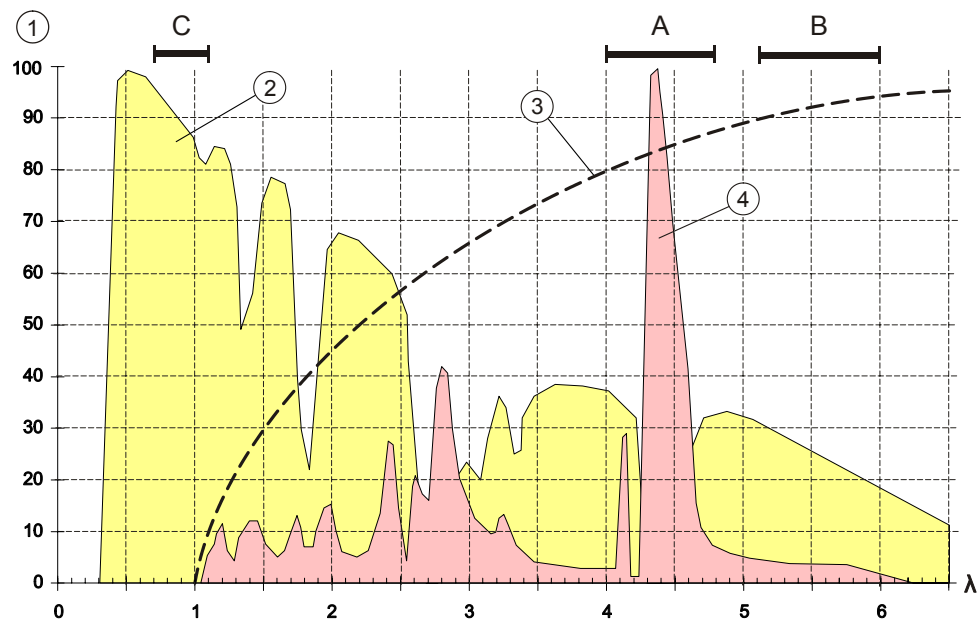

Figure 6: Spectra of solar radiation, hot objects and organic material fires

- | | |
|--|--------------------|
| 1 Radiation intensity [%] | A A-channel |
| 2 Solar radiation | B B-channel |
| 3 Hot objects | C C-channel |
| 4 Organic materials fire
In this case: Alcohol fire | λ Wave length [μm] |

3.3.1 Line separator

All FDnet/C-NET devices are equipped with a line separator.

The FDnet/C-NET device is equipped with electronic switches which isolate the defective part in case of a short-circuit on the detector line. The rest of the detector line remains serviceable.

On a loop line, all FDnet/C-NET devices remain fully functional after a single short-circuit.

3.3.2 Selftest

Flame detector FDF241-9 regularly carries out a selftest. If a fault is detected, it transmits a message to the control panel.

See also

📄 Messages to the control panel [→ 24]

3.3.3 Messages to the control panel

The flame detector can transmit the following messages to the control panel:

FDnet/C-NET operation

Message	Meaning	Measures
Danger level '0'	Normal condition	-
Danger level '3'	The flame detector has detected a fire and transmits an alarm to the control panel.	-
'Error'	The flame detector is defective. Fire detection is no longer ensured.	Replace the flame detector.
'Incorrect parameter'	A parameter set which is not available has been set. Fire detection is no longer ensured.	Select the correct parameter set.

Collective operation

Message	Meaning	Measures
'Alarm' danger level	The flame detector has detected a fire and transmits an alarm to the control panel.	-
'Fault'	<ul style="list-style-type: none"> The parameters for the flame detector are set incorrectly. OR <ul style="list-style-type: none"> The flame detector is defective. Fire detection is no longer ensured.	<ul style="list-style-type: none"> Set the parameter set correctly. OR <ul style="list-style-type: none"> Replace the flame detector.



The text shown in the messages may differ due to country-specific adaptations and control panel versions.

See also

- Determine parameter set [→ 37]
- Set parameter set [→ 53]

3.4 Accessories

3.4.1 Mounting bracket MV1

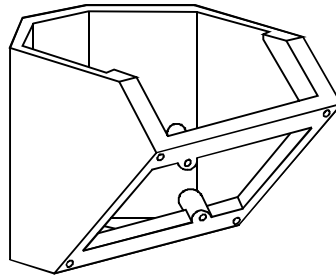

- For fixing flame detector at 45°
- Compatible with:
 - Flame detector FDF241-9
- Order number: BPZ:3950450001

3.4.2 Ball and socket joint MWV1

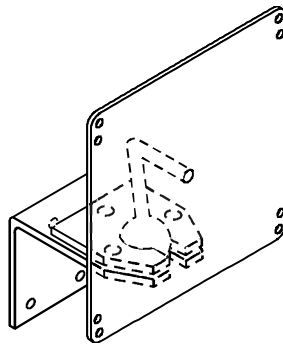

- For fixing flame detector at the angle and in the direction required
- For accurately aligning the flame detector to an area
- Compatible with:
 - Flame detector FDF241-9
- Order number: BPZ:3674840001

3.4.3 Rain hood DFZ1190

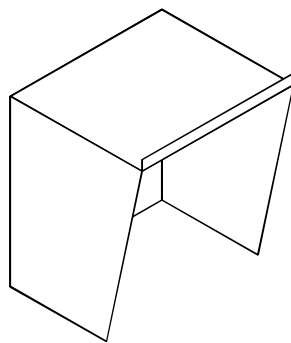

- Rain hood made of metal
- For protecting the flame detector during outdoor applications
- Compatible with:
 - Flame detector FDF241-9
- Order number: BPZ:5302660001

3.4.4 Rain hood FDFZ241

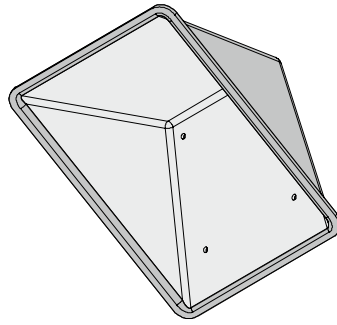

- Rain hood made of plastic
- For protecting the flame detector during outdoor applications
- Compatible with:
 - Flame detector FDF241-9
- You will find more information in document A6V10882455
- Order number: S54330-N4-A1

3.4.5 LE3 Test lamp

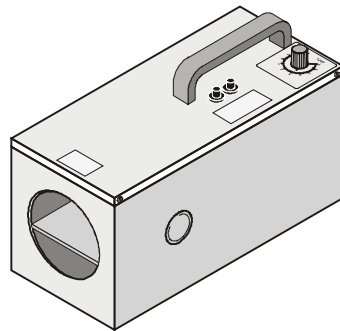

- For checking flame detectors
- Compatible with:
 - Flame detector FDF241-9
- You will find more information in document 000257
- Order number: BPZ:3669510001

3.4.6 M20 x 1.5 metal cable gland

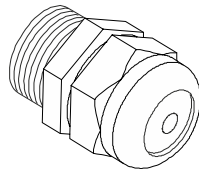

- For introducing a cable into a housing
- For cable diameters of 3.5...5.5 mm
- Temperature range: -40...+100 °C
- Allows for increased IP protection
- Compatible with:
 - M20 x 1.5 metal counter nut
 - Housing FDMH231-S-R
 - Housing FDMH292-x
 - Housing FDMH293-x
 - Housing FDMH297-R
 - Housing FDCH221
 - Manual call point FDM243H
 - Air sampling smoke detection kit FDBZ290
- Order number: A5Q00004478

3.4.7 Micro terminal DBZ1190-AA

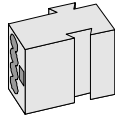

- Auxiliary terminal for connecting cables
- For T-branches of additional cabling e.g. for detector heating units, sounder base, external alarm indicators etc.
- For conductor cross-sections of 0.28...0.5 mm²
- 4-pin
- Order number: BPZ:4677080001

3.4.8 Connection terminal DBZ1190-AB

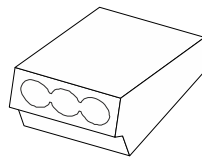

- Auxiliary terminal for connecting cables
- For T-branches of additional cabling, e.g., for cable shielding, detector heating units, sounder base, external alarm indicators, etc.
- For conductor cross-sections of 1...2.5 mm²
- 3 poles
- Order number: BPZ:4942340001

4 Planning

In this chapter you will learn how to arrange the flame detector for optimum room monitoring and how you determine the mounting site and appropriate parameter set.

Sequence

1. Establish flame detector arrangement [→ 28]
2. Defining the place of mounting [→ 32]
3. Mask deceptive phenomena [→ 36]
4. Determine parameter set [→ 37]

Information on the individual steps can be found in the specified chapters.

4.1 Establish flame detector arrangement

Select the flame detector quantity, arrangement and alignment such that the area is equally monitored. The monitoring area of a flame detector is shaped like a rotationally symmetrical taper with an opening angle of 90° .

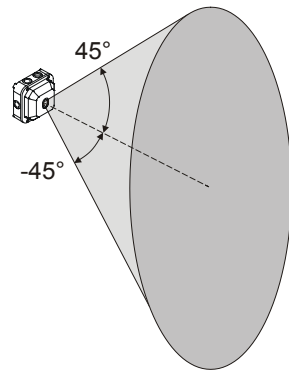

Figure 7: Monitoring area of flame detector

In a typical application, the flame detector is fitted at an angle of 45° to the wall in one of the ceiling corners.

Observe the following points during detector arrangement:

- Line of sight to area which is to be monitored
- Arrangement of several flame detectors
- Deceptive phenomena

Information on these points can be found in the following chapters. You will find several examples of application after this.

4.1.1 Line of sight

In order for the flame detector to detect a fire, the fire's infrared radiation must reach the flame detector. The infrared radiation can reach the detector through direct or indirect irradiation.

Direct irradiation:

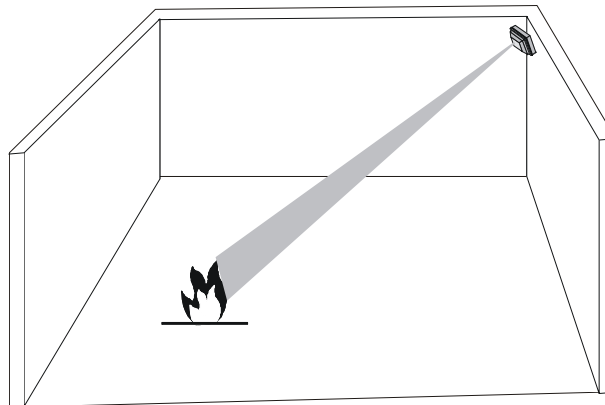

Indirect irradiation from reflections on walls, equipment etc.:

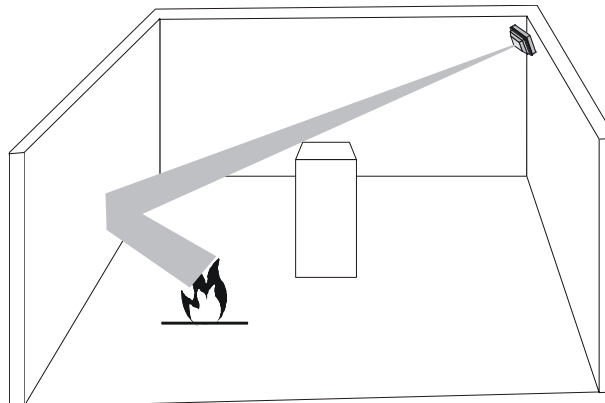

Direct irradiation is many times higher than indirect irradiation. The flame detector should therefore be positioned such that it has as direct a line of sight as possible to the entire monitoring area.

Glass and synthetic materials reduce infrared radiation so much that perfect detection is no longer possible. Avoid glass and synthetic materials between the flame detector and area being monitored.

See also

📄 Defining the place of installation [→ 32]

4.1.2 Arrangement of several flame detectors

If several flame detectors are needed in a room, they must be arranged such that as high a level of monitoring redundancy as possible is present. In other words, some of the monitoring areas of the individual flame detectors should overlap. Install the detectors such that they are opposite one another.

If you are using four flame detectors in one room, fit one detector in each corner of the room.

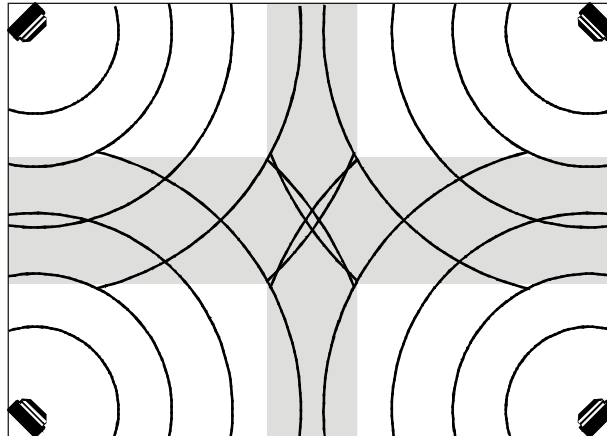

Figure 8: Arrangement of four flame detectors

If you are using two detectors in one room, install one detector in each of the opposite corners of the room.

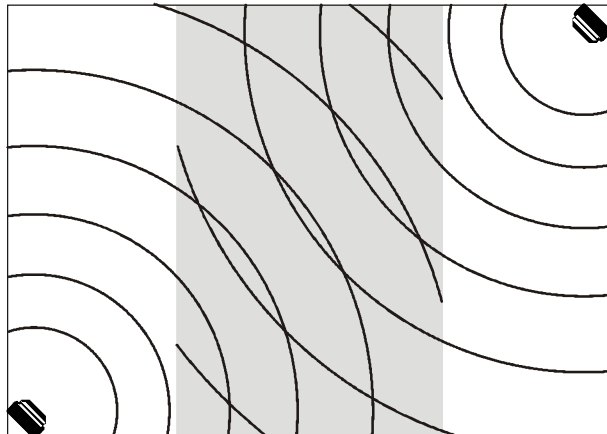

Figure 9: Arrangement of two flame detectors

See also

- 📄 Defining the place of installation [→ 32]

4.1.3 Deceptive phenomena

When arranging the flame detector, take possible deceptive phenomena into account and take appropriate measures. Deceptive phenomena which may activate the flame detector and trigger a false alarm are listed below.

- Direct and indirect solar radiation
- Hot objects, such as hot motors
- Arc welding
- Moving parts between the flame detector and a hot object, such as air hoses from the exhaust system in the motor test bed
- Light from halogen lamps without protective glass

To prevent a false alarm, use an appropriate parameter set or use masks to hide the deceptive phenomenon.

See also

- 📄 Mask deceptive phenomena [→ 36]
- 📄 Determine parameter set [→ 37]

4.1.4 Examples of application

The flame detectors are installed in such a way that fires can be detected in spite of possible obstacles such as airfoils from aircraft or cranes.

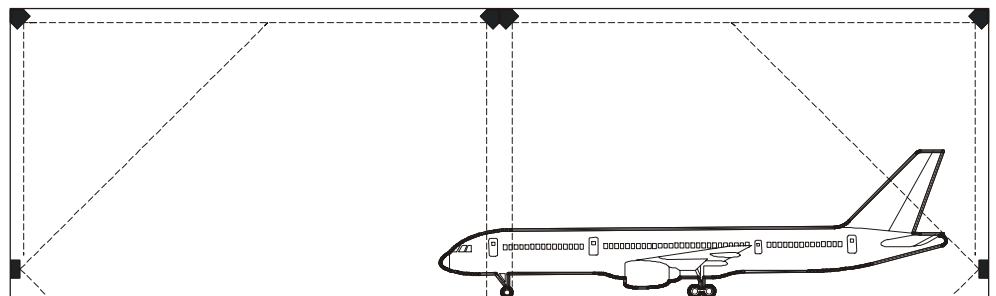

Figure 10: Flame detector in an aircraft hangar

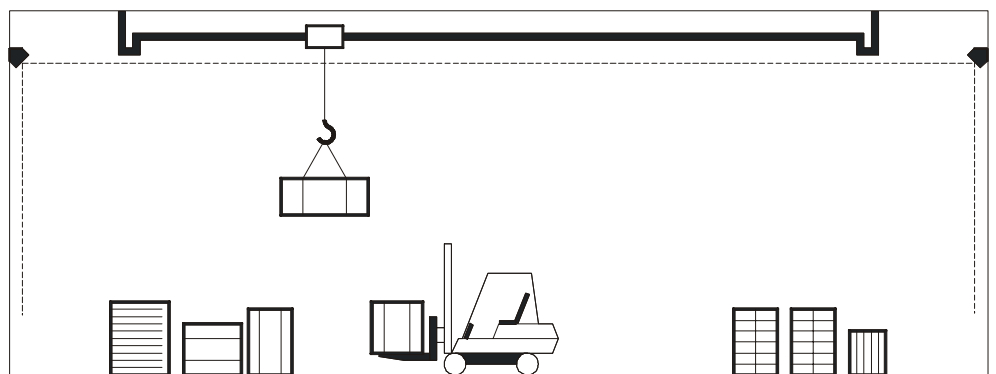

Figure 11: Flame detector in a freight forwarding hall

4.2 Defining the place of installation

To determine where to install the flame detector, you must first calculate the maximum detection distance d and then the maximum mounting height h . You can use these measurements to split the area requiring monitoring into one or more cubes. Each cube is monitored by one flame detector which is mounted in one corner of the cube at 45° .

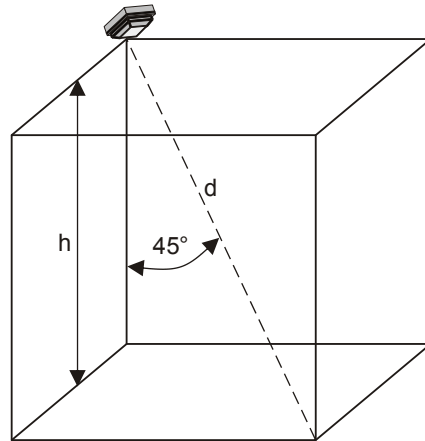

Figure 12: Cube as planning basis for determining the site of mounting

Detection distance d corresponds to the cube's space diagonal and is the maximum distance between the flame detector and area being monitored.

Mounting height h corresponds to the cube's side length and is the flame detector's maximum mounting height.



The area is only split into cubes as a basis for planning. The cube does not correspond to the monitoring area. See also in this connection chapter 'Establish flame detector arrangement [→ 28]'.

You will find information on how to calculate detection distance d and mounting height h in the following chapters.



⚠ WARNING

Unforeseeable flame behavior due to air circulation

Fire is not detected

- Only use all the calculations provided below for areas with little air circulation.
- If you want to use the flame detector in areas with high levels of air circulation, please talk to your Siemens contact.

See also

- 📄 Calculate detection distance [→ 33]
- 📄 Calculate mounting height [→ 35]
- 📄 Establish flame detector arrangement [→ 28]

4.2.1 Calculate detection distance

The maximum detection distance of a flame detector depends on the following factors:

- Detector sensitivity
- Fire size
- Directional sensitivity
- Fuel

Various correction coefficients therefore need to be taken into account when calculating the maximum detection distance.

Formula for calculating maximum detection distance d

$$d = S \times \sqrt{\frac{G_g}{G_b}} \times K \times F$$

- d Detection distance
- S Correction coefficient for detector sensitivity
- G_g Fire size wanted
- G_b Basic fire size
- K Correction coefficient for directional sensitivity
- F Correction coefficient for fuel

The correction coefficients for calculating the detection distance are described in the following sections.



The detection distance is reduced by up to 15 % by films of oil or water on the flame detector's protective glass.

Correction coefficient S for detector sensitivity

The table below shows the correction coefficients for detector sensitivity. Only select 'High' detector sensitivity if there are no deceptive phenomena.

Detector sensitivity	Correction coefficient S
Normal	23
High	46

Fire size wanted G_g

The fire size wanted G_g is the minimum size of the fire that is to be detected. The smaller the fire, the shorter the detection distance. Choose the basic area of the fire in m² for G_g.

Basic fire size G_b

The basic fire size G_b is constant and is 0.25 m².

Correction coefficient K for directional sensitivity

The detection distance depends on the flame detector's vision angle. The following diagram shows the correction coefficients for various vision angles.

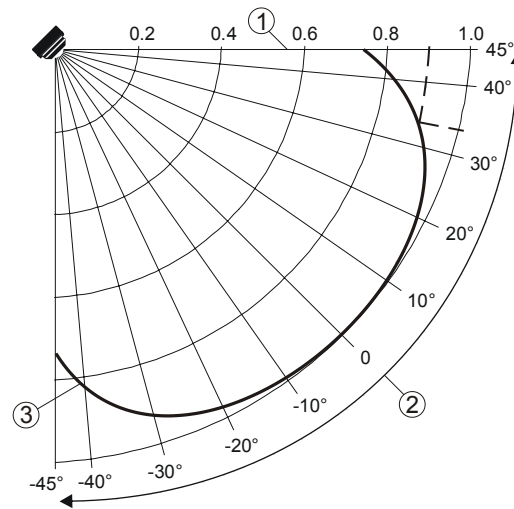

Figure 13: Correction coefficients for directional sensitivity

- 1 Correction coefficient K 3 Directional sensitivity
 2 Vision angle

Example: The correction coefficient for a vision angle of 34° is 0.9.

Correction coefficient F for fuel

Fuel also affects the detector's detection distance. The table below shows the correction coefficients for various fuels.

Fuel	Correction coefficient F
Acetone	1.5
Diesel, heating oil	0.8
Ethanol	1.0
Heptane	1.5
Kerosene	1.0
Methanol	0.8
Crude oil	1.0

Example of how to calculate the maximum detection distance

Calculate the maximum detection distance for a heptane fire, 0.1 m² in size. The flame detector has a 'Normal' detector sensitivity and a vision angle of 0°.

Known:

S	Correction coefficient for detector sensitivity	23
Gg	Fire size wanted	0.1 m ²
Gb	Basic fire size	0.25 m ²
K	Correction coefficient for directional sensitivity	1
F	Correction coefficient for fuel	1.5

$$d = S \times \sqrt{\frac{Gg}{Gb}} \times K \times F = 23 \text{ m} \times \sqrt{\frac{0.1 \text{ m}^2}{0.25 \text{ m}^2}} \times 1 \times 1.5 = 21.82 \text{ m}$$

The maximum detection distance is 21 m.

4.2.2 Calculate mounting height

In order to calculate the maximum mounting height h, you need to know detection distance d.

Formula for calculating maximum mounting height h

$$h = \frac{d}{\sqrt{3}}$$

h Mounting height

d Detection distance

Example of how to calculate the maximum mounting height

Calculate the maximum mounting height given a detection distance of 21 m.

Known:

Detection distance d = 21 m

$$h = \frac{d}{\sqrt{3}} = \frac{21 \text{ m}}{\sqrt{3}} = 12.12 \text{ m}$$

The maximum mounting height is 12 m.

4.3 Mask deceptive phenomena

If the monitoring area has deceptive phenomena, you can use masks. There are two ways of using masks:

- Use masks to limit the vision angle of the flame detector such that the detector does not detect the deceptive phenomenon.

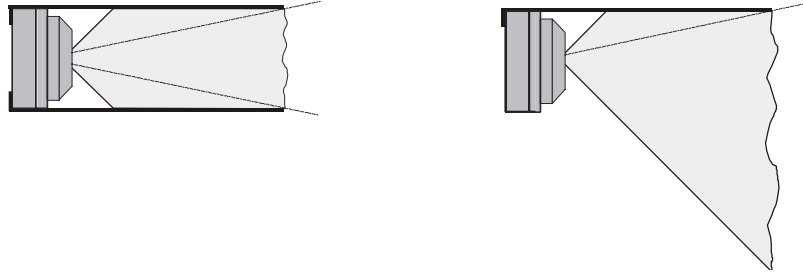

- Secure the masks around the deceptive phenomenon so that the detector does not detect the deceptive phenomenon.

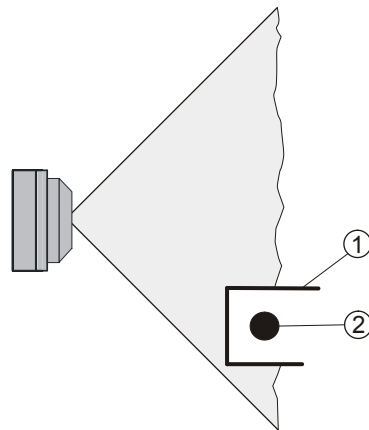

1 Mask

2 Deceptive phenomenon

The masks must be made from non-reflecting material which is impervious to infrared.

Example: Aluminum sheet 1 mm thick

4.4 Determine parameter set

A parameter set can be used to set the flame detector perfectly to the ambient features.

The individual parameter sets differ in terms of the following characteristics:

- Detector sensitivity
- Integration time
- Resistance to deceptive phenomena

Detector sensitivity

The following detector sensitivities are available:

High	Satisfies class 1 according to EN 54-10
Normal	Satisfies class 2 according to EN 54-10

In accordance with EN 54-10, detectors are split into three classes depending on the distance from which they can detect standard fires.

Class of detectors	Detector sensitivity	Detection distance
1	High	≤25 m
2	Normal	≤17 m
3	Normal	≤12 m

Table 1: Sub-division into classes of detectors according to EN 54-10

Integration time

The integration time determines how long the detector analyzes the signal for before deciding whether an alarm should be activated. The following integration times are available:

- Very short: 1 second
- Short: 3 seconds
- Medium: 6 seconds
- Very long: 12 seconds



The integration time is not the same as the response time.

Resistance to deceptive phenomena

Flame detector FDF241-9 has parameter sets which take account of the following deceptive phenomena:

- Direct solar radiation
- Hot objects
- Arc welding

4.4.1 Parameter sets for FDF241-9

The table below shows the parameter sets for flame detector FDF241-9:

Parameter set		Sensitivity	Integration	Resistance to deceptive phenomena		
No.	Name			Solar radiation	Hot objects	Arc welding
01	Robust	Normal (class 2)	Very long	X	X	X
02	Universal	Normal (class 2)	Medium	X	X	X
03	Universal fast	Normal (class 2)	Short	X	X	X
04	Sensitive	High (class 1)	Medium	-	X	-
05	Sensitive fast	High (class 1)	Short	-	-	-
06	Rapid	High (class 1)	Very short	-	-	-
07	Motor test bed	High (class 1)	Very long	X	-	-
14	Download 1	Application-specific parameter set				
15	Download 2	Application-specific parameter set				

Table 2: Parameter sets for flame detector FDF241-9

Typical applications for parameter sets

Robust (01)

This parameter set is suited to halls where deceptive phenomena such as flying sparks, molten metals or strong solar radiation can be expected. Examples: Foundry, hardening shop, electric arc welding site, open ferry boat.

Universal (02)

This parameter set is suited to rooms where a normal fire growth can be expected. Examples: Battery room, machine room on ships, transformer station.

Universal fast (03)

This parameter set is suited to rooms where a rapid fire growth can be expected and there is a high danger to life. Example: Warehouse for chemicals.

Sensitive (04)

This parameter set is suited to large halls or outdoor applications where a normal fire growth can be expected. Examples: Industrial storage room, print shop, wood storage, atrium, recycling facility, ferry, cargo ship, tunnel.

Sensitive fast (05)

This parameter set is suited to halls and sites where a rapid fire growth can be expected and where even the smallest of flames will result in major damage. Examples: Fuel storage room, pumping station, petrochemical facility, aircraft hangar.

Rapid (06)

This parameter set is suited to protection of physical assets. Small flames possibly caused by processes must be detected immediately. The risk of false alarms is accepted. Example: Conveyor belt transporting combustible products from a furnace to the packaging area.

Motor test bed (07)

This parameter set is suited to motor test beds.

Download 1 (14) and download 2 (15)

These application-specific parameter sets can be downloaded locally and depend on the control panel used.

5 Mounting / Installation

This chapter explains how you install the base for flame detector and how you connect the flame detector to the detector line.

Prerequisites

- The flame detector's mounting site is determined following to the details provided in the 'Planning [→ 28]' chapter.
- The supply network is produced, connected and checked in line with the country-specific installation guidelines.

Sequence

1. Switch flame detector over to collective operation [→ 40] (if required)
2. Fit base for flame detector [→ 42]
3. Electrical connection [→ 44]

You will find information on the individual steps in the specified chapters.



The flame detector is only fitted on the base for flame detector when commissioning.

See also

- 📄 Planning [→ 28]

5.1 Switch flame detector over to collective operation

When supplied the flame detector is set for operation on an FDnet/C-NET detector line. When operating a collective detector line, the control panel normally automatically switches the flame detector to collective operation.

Some collective control panels do not however automatically switch from FDnet/C-NET operation to collective operation. In these cases, you must switch the flame detector over manually. If you are not certain whether the flame detector is switched over automatically, switch it manually to collective operation before mounting.

The detector always switches automatically from collective operation to FDnet/C-NET operation.

Procedure



Note the positive and negative poles.

▷ The flame detector is not connected to the detector line.

1. Connect the base for the flame detector to a DC 12...28 V source of DC voltage, e.g. a battery, following the connection diagram shown below. Use a screwdriver to remove the load from the socket strip so you can slide in the wire.
2. Remove bridging connector (2) from base for flame detector.

3. Connect the connection cable supplied (1) to the connections (3) in the base for flame detector and on the flame detector.
 4. Wait around 15 seconds and then remove the connection cable and source of DC voltage.
- ⇒ The flame detector is switched over to collective operation and can be connected to a collective detector line.

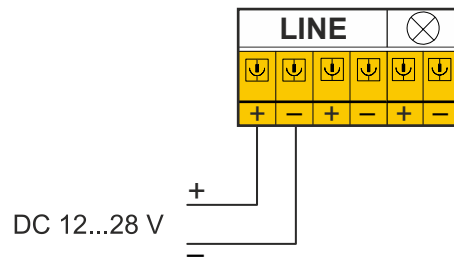

Figure 14: Connection diagram for the source of DC voltage

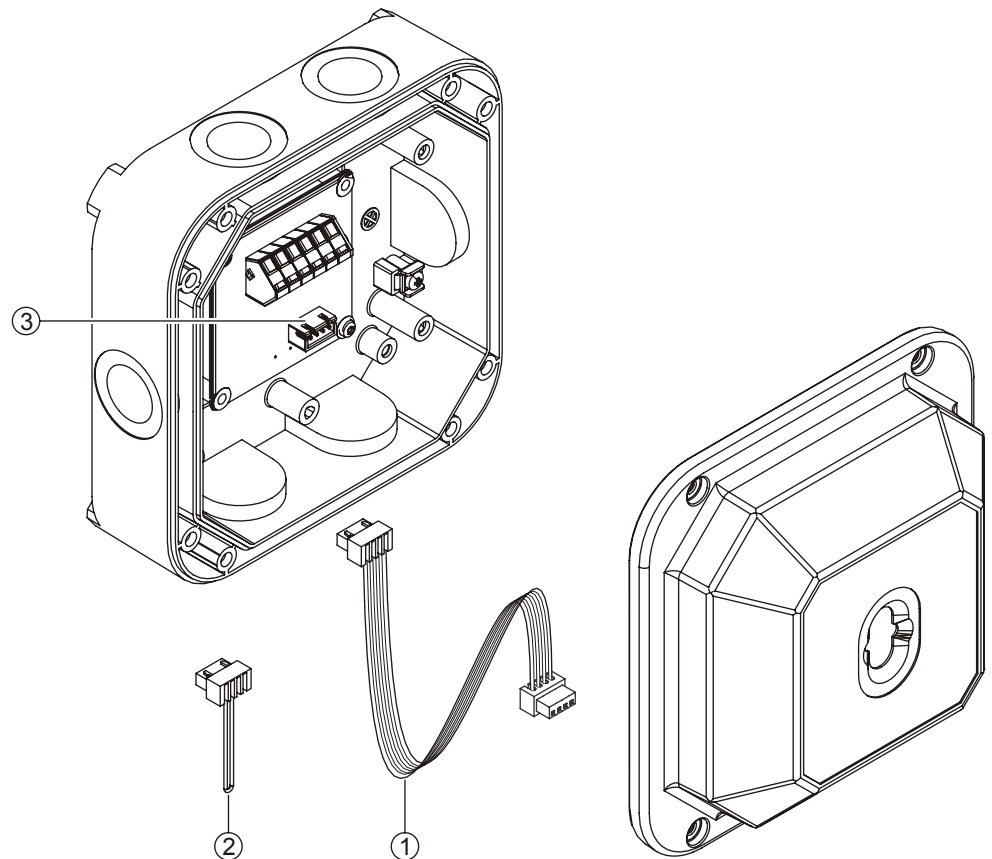



Figure 15: Switching flame detector over to collective operation

1 Connection cable

2 Bridging connector

3 Connection for connection cable

5.2 Fit base for flame detector

	⚠ WARNING
	<p>Danger of falling Bodily injury</p> <ul style="list-style-type: none"> • When installing, use a secured ladder or work platform.

	⚠ CAUTION
	<p>Using the device in a damp and/or corrosive environment Device function is impaired.</p> <ul style="list-style-type: none"> • Use the M20 x 1.5 metal cable gland in damp and/or corrosive environments.

1. If necessary, mount the mounting bracket, ball and socket joint, or a rain hood according to local conditions. You will find information about these accessories in the chapter 'Accessories [→ 25]'
 2. Break open the plastic parts in the base for flame detector at the openings you require for cable entry (1).
 3. If necessary screw the M20 x 1.5 metal cable gland into the openings.
 4. Use four screws (2) to fit the base for flame detector on the mounting bracket, ball and socket joint, rain hood or directly on a stable, vibration-free surface.
- ⇒ The base for flame detector is fitted.

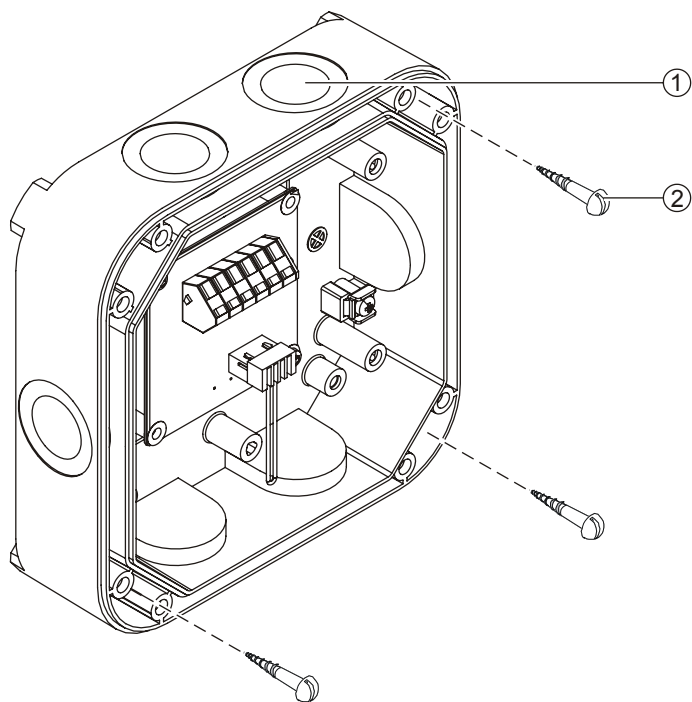

Figure 16: Mounting of base for flame detector

1 Six openings for cable entry

2 Four screws for installing the base for flame detector

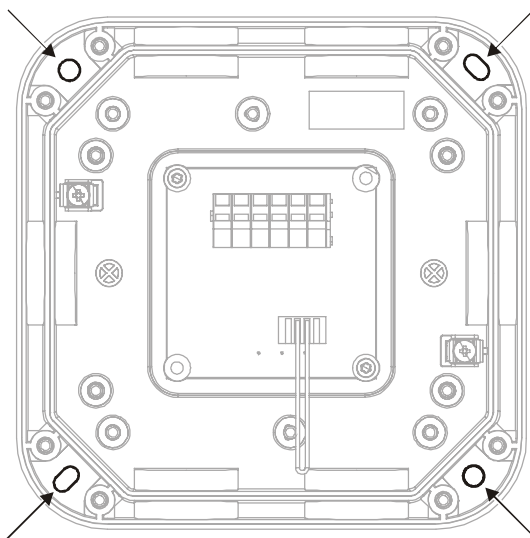

Figure 17: Openings for installing base for flame detector

5.3 Electrical connection



- Specialist electrical engineering knowledge is required for installation.
 - Only an expert is permitted to carry out installation work.
- Incorrect installation can take safety devices out of operation unbeknown to a layperson.

The electrical connection depends on the following factors:

- Connection to an FDnet/C-NET detector line or collective detector line
- Use of unshielded cables or shielded cables

The general process is described below. The connection diagrams and more information on the various connection variants can be found in the following chapters.

Note the following with regard to the electrical connection:



⚠ CAUTION

Using the device in a damp and/or corrosive environment

Device function is impaired.

- Use the M20 x 1.5 metal cable gland in damp and/or corrosive environments.



Note the positive and negative poles.

Only connect one wire per terminal. This is the only way to ensure the connection is failure-free for the entire service life of the device.

- Wherever possible use twisted, unshielded cables. Shielded cables are only required in special cases, such as strong high-frequency fields. This also applies to connecting the external alarm indicators.
- Only use cables with a conductor cross-section of 0.2...1.5 mm².

General procedure

- ▷ The base for flame detector is fitted.
 - ▷ The plastic parts on the openings for cable entry are broken open.
1. Guide the cables from the detector line and external alarm indicator into the base for flame detector.
 2. Connect the wires as shown in the corresponding connection diagram. Use a screwdriver to remove the load from the socket strip so you can slide in the wire.

See also

- 📄 Connection to an addressed detector line [→ 45]
- 📄 Connection to a collective detector line [→ 47]

5.3.1 Connection to an addressed detector line

The following applies to FDnet/C-NET detector lines:

- Loops, stubs and T-branches are possible.
- You may only connect external alarm indicators to **one** detector.
- Permissible cables for detectors with more than one external alarm indicator according to the collective connection diagram may be migrated to the FDnet/C-NET without any changes.
- Note document 001508 for installation (calculation of the capacity layer).

5.3.1.1 Use of unshielded cables

The connection is established from base to base using twisted or non-twisted wire pairs.

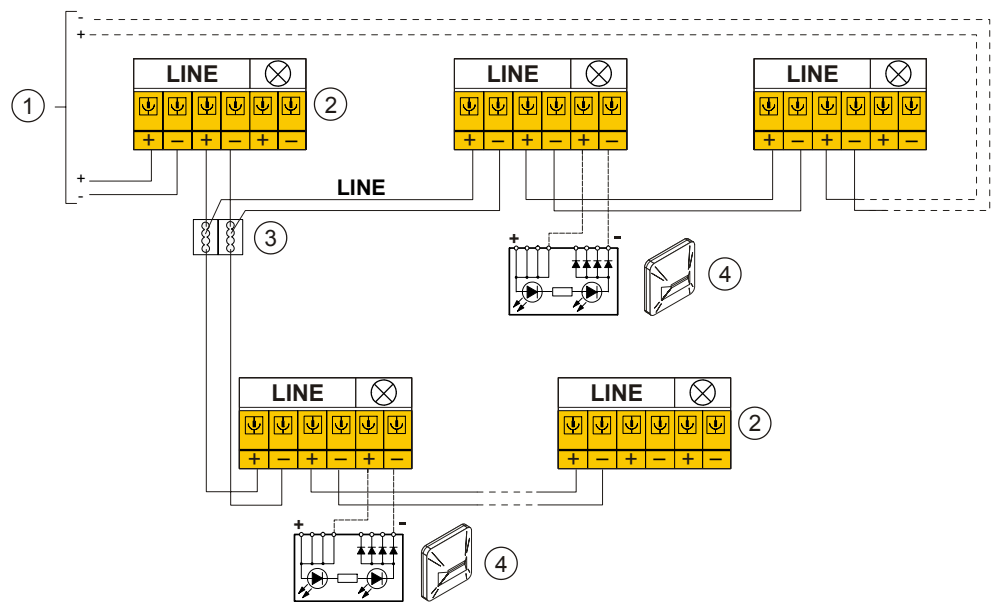

Figure 18: Connection diagram for addressed detector line with and without external alarm indicators (without shielded cables)

- 1 Control panel
- 2 Detector

- 3 Auxiliary terminals DBZ1190-xx
- 4 External alarm indicator

5.3.1.2 Use of shielded cables

The detector line shielding must be connected through in the detector base with auxiliary terminals DBZ1190-xx.

There are two ways of connecting external alarm indicators:

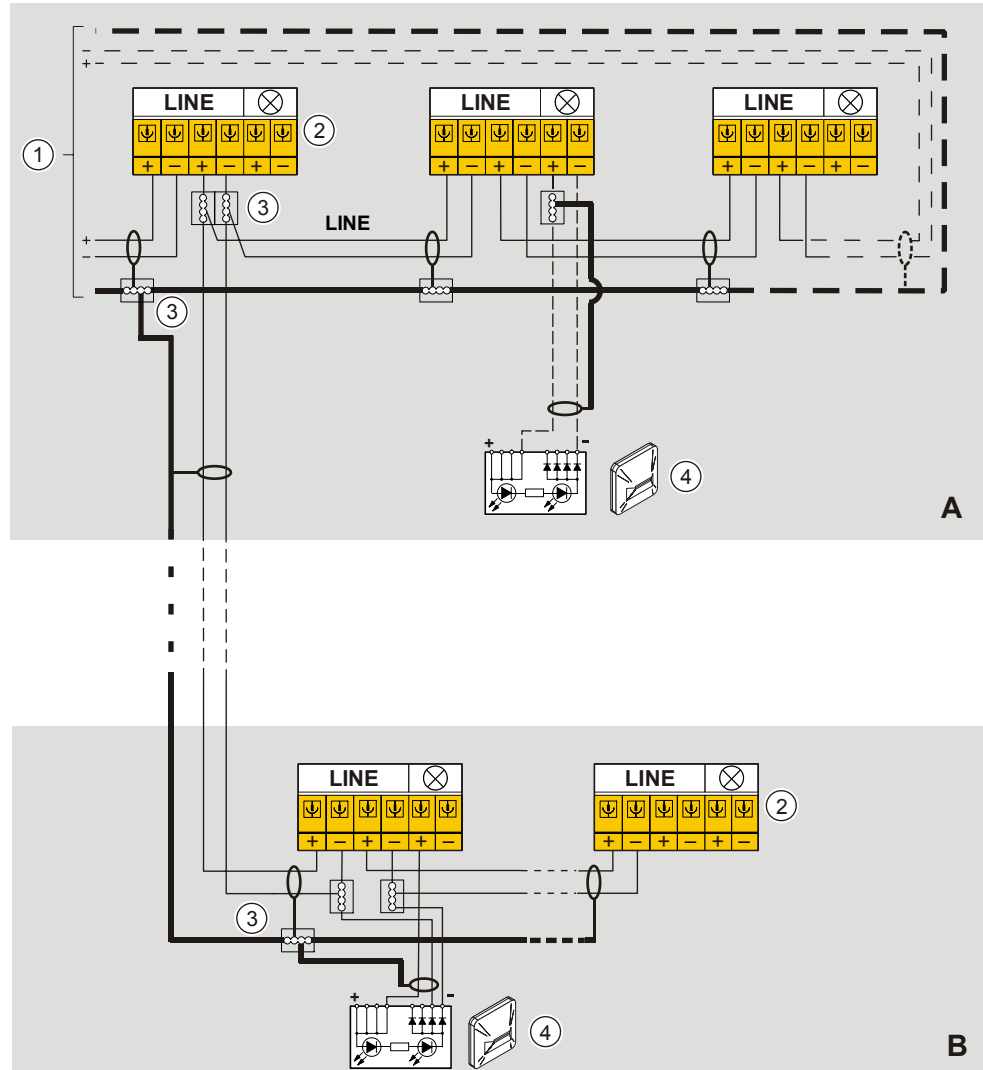

Figure 19: Connection diagram for addressed detector line with and without external alarm indicators (with shielded cables)

- | | |
|-----------------|----------------------------------|
| 1 Control panel | 3 Auxiliary terminals DBZ1190-xx |
| 2 Detector | 4 External alarm indicator |

Variant A

1. Connect the positive pole of the external alarm indicator to the positive pole for the external alarm indicator on the detector.
2. Connect the negative pole of the external alarm indicator to the negative pole for the external alarm indicator on the detector.
3. Connect the shielding of the connection cable between the external alarm indicator and detector on the detector side to the positive pole for the external alarm indicator via an auxiliary terminal DBZ1190-xx.

Variant B

1. Connect the positive pole of the external alarm indicator to the positive pole for the external alarm indicator on the detector.
2. Leave the negative pole for the external alarm indicator on the detector unoccupied.
3. Connect each of the two negative poles of the external alarm indicator separately to both negative poles of the detector line.



The two negative connections of the external alarm indicator are decoupled externally in the alarm indicator by diodes.

4. Connect the shielding of the detector line with the shielding of the connection cable to the external alarm indicator with an auxiliary terminal DBZ1190-xx.

5.3.2 Connection to a collective detector line

Connect a control panel-specific end-of-line to the end of the collective detector line.

5.3.2.1 Use of unshielded cables

The connection is established from base to base using twisted or non-twisted wire pairs.

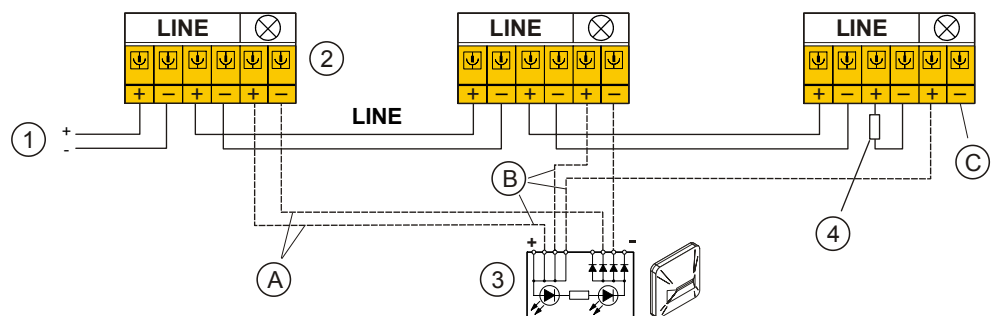

Figure 20: Connection diagram for collective detector line with and without external alarm indicators (without shielded cables)

- | | |
|-----------------|--|
| 1 Control panel | 3 External alarm indicator |
| 2 Detector | 4 End-of-line depending on control panel |

Standard circuitry

With standard circuitry, the external alarm indicator is connected to the positive and negative poles of each detector.

Wire-saving cabling



NOTICE

Cabling for new sites

Wire-saving cabling in external alarm indicators is prohibited for new sites.

With wire-saving cabling, the external alarm indicator is connected as follows:

- The external alarm indicator must be connected to the positive and negative poles of at least one detector (A).
- The external alarm indicator must be connected to the positive pole of every other detector (B).
- The external alarm indicator need not be connected to the negative pole of every other detector (C).

5.3.2.2 Use of shielded cables

The detector line shielding must be connected through in the detector base with auxiliary terminals DBZ1190-xx.

There are two ways of connecting external alarm indicators:

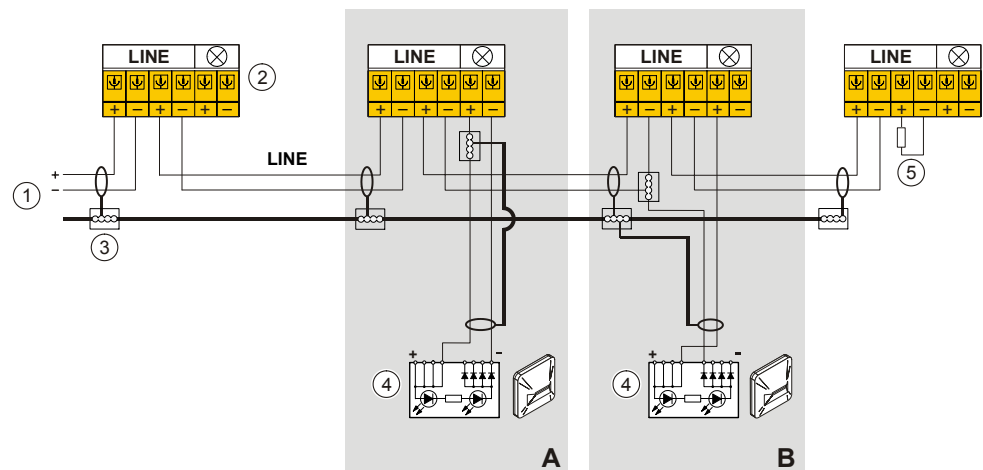

Figure 21: Connection diagram for collective detector line with and without external alarm indicators (with shielded cables)

- | | |
|----------------------------------|--|
| 1 Control panel | 4 External alarm indicator |
| 2 Detector | 5 End-of-line depending on control panel |
| 3 Auxiliary terminals DBZ1190-xx | |

Variant A

1. Connect the positive pole of the external alarm indicator to the positive pole for the external alarm indicator on the detector.
2. Connect the negative pole of the external alarm indicator to the negative pole for the external alarm indicator on the detector.
3. Connect the shielding of the connection cable between the external alarm indicator and detector on the detector side to the positive pole for the external alarm indicator via an auxiliary terminal DBZ1190-xx.

Variant B

1. Connect the positive pole of the external alarm indicator to the positive pole for the external alarm indicator on the detector.
2. Leave the negative pole for the external alarm indicator on the detector unoccupied.
3. Connect the negative pole of the external alarm indicator with the negative pole on the input side of the detector line on the detector via an auxiliary terminal DBZ1190-xx.
4. Connect the shielding of the detector line with the shielding of the connection cable to the external alarm indicator via an auxiliary terminal DBZ1190-xx.

6 Commissioning

This chapter explains how you set the parameter set and how you commission the flame detector on the detector line. The commissioning process depends on whether you are using an addressed detector line (FDnet/C-NET) or a collective detector line.

See also

- 📄 Commissioning an addressed detector line [→ 50]
- 📄 Commissioning on a collective detector line [→ 53]

6.1 Commissioning an addressed detector line

Sequence

1. Install flame detector on base for flame detector [→ 50]
2. Set parameter set [→ 52]
3. Run performance check [→ 52]

You will find information on the individual steps in the specified chapters.

6.1.1 Install flame detector on base for flame detector

	⚠ WARNING
	Danger of falling Bodily injury <ul style="list-style-type: none"> • When installing, use a secured ladder or work platform.

	⚠ WARNING
	Falling flame detector Bodily injury <ul style="list-style-type: none"> • Never leave the flame detector hanging with the connection cable connected to the base for flame detector.

1. Remove bridging connector (3) from base for flame detector.
 2. Use the connection cable (2) to connect connections (4) in the base for flame detector and on the flame detector.
 3. Use four screws (1) to secure the flame detector to the base for flame detector.
- ⇒ The flame detector is fitted.

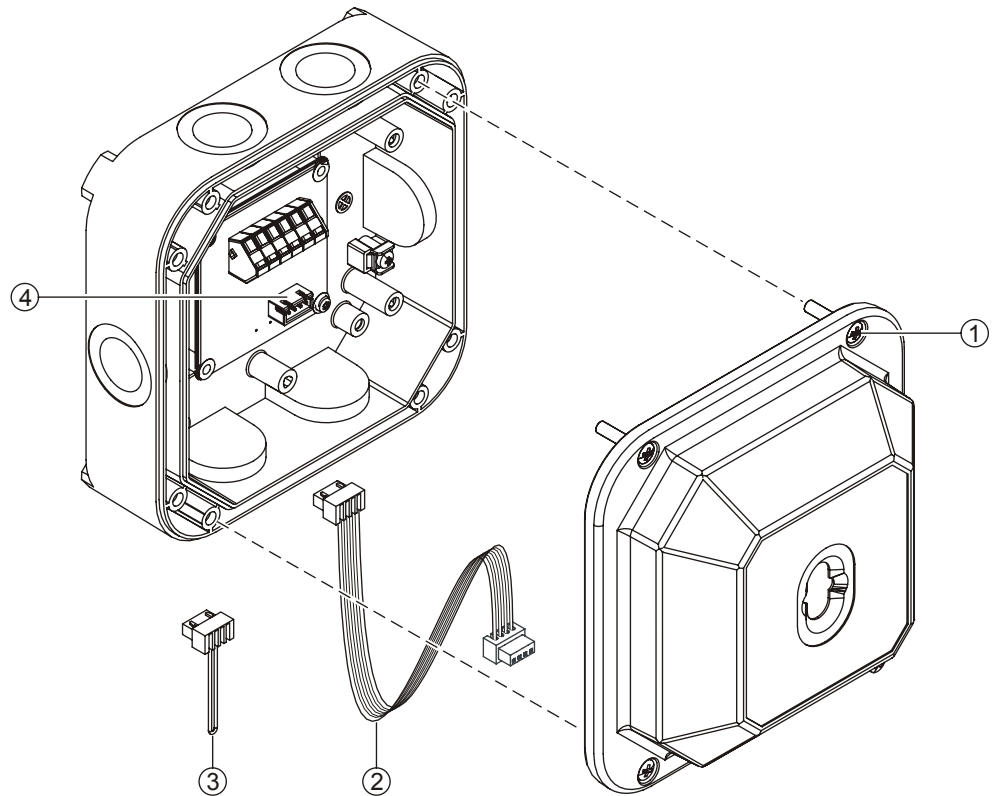

Figure 22: Mounting of flame detector on base for flame detector

1 Four screws for mounting

2 Connection cable

3 Bridging connector

4 Connection for connection cable

6.1.2 Set parameter set

Once the detector line has been read in, you need to set the parameter set. When in FDnet/C-NET operation, the DIP switches in the flame detector are not active. Use the control panel to set the parameter set you want. The table below shows the parameter sets and associated numbers.

No.	Parameter set
01	Robust
02	Universal
03	Universal fast
04	Sensitive
05	Sensitive fast
06	Rapid
07	Motor test bed
14	Download 1
15	Download 2

Table 3: Parameter sets for FDF241-9

The procedure for setting the parameter set via the control panel is described in the control panel documentation.

See also

 Determine parameter set [→ 37]

6.1.3 Run performance check

Use test lamp LE3 or a test fire to check the function of the flame detector. The procedure control is described in the chapter 'Performance check [→ 56]'.

See also

 Performance check [→ 56]

6.2 Commissioning on a collective detector line

Sequence

1. Set parameter set [→ 53]
2. Install flame detector on base for flame detector [→ 54]
3. Run performance check [→ 55]

You will find information on the individual steps in the specified chapters.

6.2.1 Set parameter set

For collective operation, the parameter set is set via the DIP switches in the flame detector.

Procedure

- ▷ The parameter set is determined according to the details provided in the 'Planning [→ 28]' chapter.
1. Loosen screw (3) on rear of flame detector.
 2. Open swiveling cover (1).
 3. Use DIP switches (2) to set the parameter set you want (see table below).
 4. Close swiveling cover (1) and fix with screw (3).
- ⇒ The parameter set is set.

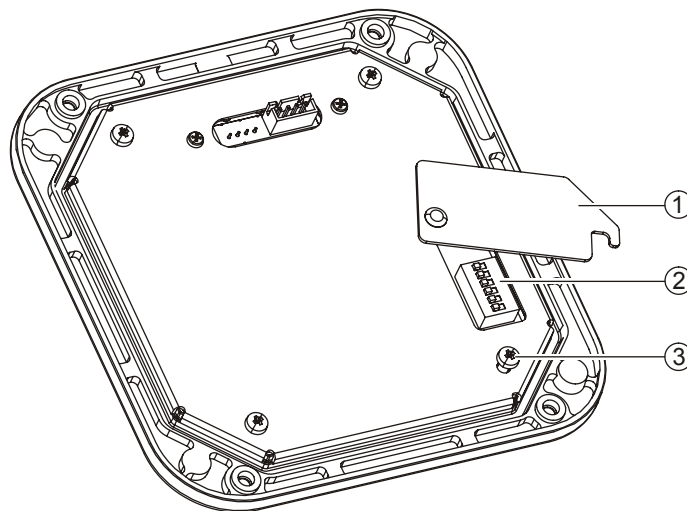

Figure 23: Rear of flame detector with open swiveling cover

1 Swiveling cover



2 DIP switch

3 Screw for fixing swiveling cover

Parameter set		DIP switch					
No.	FDF241-9	1	2	3	4	5	6
01	Robust	<input checked="" type="checkbox"/>	<input type="checkbox"/>	<input type="checkbox"/>	<input type="checkbox"/>	<input type="checkbox"/>	<input type="checkbox"/>
02	Universal	<input type="checkbox"/>	<input checked="" type="checkbox"/>	<input type="checkbox"/>	<input type="checkbox"/>	<input type="checkbox"/>	<input type="checkbox"/>
03	Universal fast	<input checked="" type="checkbox"/>	<input checked="" type="checkbox"/>	<input type="checkbox"/>	<input type="checkbox"/>	<input type="checkbox"/>	<input type="checkbox"/>
04	Sensitive	<input type="checkbox"/>	<input type="checkbox"/>	<input checked="" type="checkbox"/>	<input type="checkbox"/>	<input type="checkbox"/>	<input type="checkbox"/>
05	Sensitive fast	<input checked="" type="checkbox"/>	<input type="checkbox"/>	<input checked="" type="checkbox"/>	<input type="checkbox"/>	<input type="checkbox"/>	<input type="checkbox"/>
06	Rapid	<input type="checkbox"/>	<input checked="" type="checkbox"/>	<input checked="" type="checkbox"/>	<input type="checkbox"/>	<input type="checkbox"/>	<input type="checkbox"/>
07	Motor test bed	<input checked="" type="checkbox"/>	<input checked="" type="checkbox"/>	<input checked="" type="checkbox"/>	<input type="checkbox"/>	<input type="checkbox"/>	<input type="checkbox"/>

Table 4: Set parameter set

See also

-  Determine parameter set [→ 37]
-  Planning [→ 28]

6.2.2 Install flame detector on base for flame detector

	⚠ WARNING
	Danger of falling Bodily injury <ul style="list-style-type: none"> • When installing, use a secured ladder or work platform.

	⚠ WARNING
	Falling flame detector Bodily injury <ul style="list-style-type: none"> • Never leave the flame detector hanging with the connection cable connected to the base for flame detector.

1. Remove bridging connector (3) from base for flame detector.
 2. Use the connection cable (2) to connect connections (4) in the base for flame detector and on the flame detector.
 3. Use four screws (1) to secure the flame detector to the base for flame detector.
- ⇒ The flame detector is fitted.

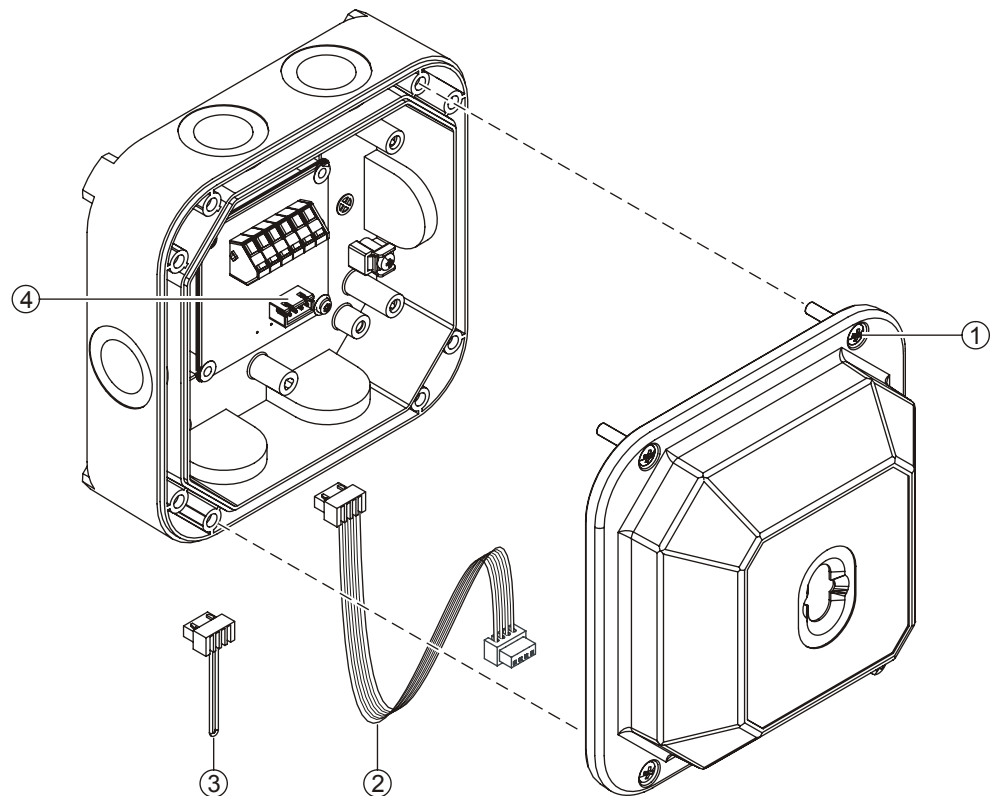

Figure 24: Mounting of flame detector on base for flame detector

- | | |
|----------------------------|-----------------------------------|
| 1 Four screws for mounting | 3 Bridging connector |
| 2 Connection cable | 4 Connection for connection cable |

6.2.3 Run performance check

Use test lamp LE3 or a test fire to check the function of the flame detector. The procedure control is described in the chapter 'Performance check [→ 56]'.

See also

- 📄 Performance check [→ 56]

7 Maintenance / Repair

This chapter explains how to run a performance check, what you can do if the flame detector is not functioning correctly and how you can clean the flame detector.

7.1 Performance check

Use test lamp LE3 or a test fire to check the function of the flame detector on an annual basis.

Performance check with test lamp LE3

1. On the control panel, switch off the remote transmission of alarms. To do this set the 'Detector test' operating mode on the control panel.
2. Use test lamp LE3 to check the flame detector. Note the information in document 000257. The maximum distance between test lamp and flame detector depends on the set parameter set (see table below).
 - ⇒ The flame detector activates an alarm within 20 seconds.
 - ⇒ The alarm indicator on the flame detector flashes.
3. On the control panel, switch the remote transmission of alarms back on.
 - ⇒ The flame detector is ready.

You will find more detailed information in the fire detection system documentation.

No.	Parameter set	Distance
1	Robust	6 m
2	Universal	6 m
3	Universal fast	6 m
4	Sensitive	8 m
5	Sensitive fast	8 m
6	Rapid	13 m
7	Motor test bed	13 m

Table 5: Maximum distance between test lamp and flame detector depends on parameter set

If the flame detector does not activate an alarm, follow the actions described in the 'Troubleshooting' chapter.

Performance check with a test fire



⚠ WARNING

Fire hazard from test fire

Bodily injury and material damage

- Only specially trained persons may undertake test fires. These persons must be trained in how to handle fire extinguishers.
- The size of the test fire depends on the room height.

1. On the control panel, switch off the remote transmission of alarms. To do this set the 'Detector test' operating mode on the control panel.
2. Use a test fire to test the flame detector. Note the information in document 009977.
 - ⇒ The flame detector activates an alarm within 20 seconds.
 - ⇒ The alarm indicator on the flame detector flashes.
3. On the control panel, switch the remote transmission of alarms back on.
 - ⇒ The flame detector is ready.

You will find more detailed information in the fire detection system documentation. If the flame detector does not activate an alarm, follow the actions described in the 'Repair [→ 58]' chapter.

See also

📄 Repair [→ 58]

7.2 Cleaning

The flame detector sensors must be clearly visible through the protective glass. Proceed as follows if this is not the case:

1. Clean the protective glass from the outside with a soft, damp cloth. Washing-up liquid may be used if the glass is very dirty.
2. Carry out a function check [→ 56].

See also

📄 Performance check [→ 56]

7.3 Repair

Problem

The flame detector does not activate an alarm during the performance check.

Remedy

- Ensure that the flame detector is registered on the control panel.

If the problem persists:

- Ensure that the protective glass on the flame detector is clean and the sensors are clearly visible. Clean the protective glass if this is not the case.

If the problem persists:

- Replace the flame detector.

See also

 [Cleaning \[-> 57\]](#)

8 Specifications

8.1 Technical data

You will find information on approvals, CE marking, and the relevant EU directives for this device (these devices) in the following document(s); see 'Applicable documents' chapter:

- Document 007012

FDnet/C-NET detector line	Operating voltage	DC 12...33 V
	Operating current (quiescent)	0.7 mA
	Maximum current connection factor	3
	Quiescent current connection factor	3
	Address connection factor	1
	Separator connector factor	1
	Protocol	FDnet/C-NET
	Compatibility	See 'List of compatibility'
Collective detector line	Operating voltage	DC 14...28 V
	Operating current (quiescent)	0.5 mA
	Making current	Max. 0.75 mA
	Connection factor	5
	Alarm voltage at alarm current:	
	• 1...15 mA	DC 5...10 V
	• 35 mA	DC 18...22 V
	• 50 mA	DC 26...28 V
	Alarm current at operating voltage DC 5...28 V	4...50 mA
	Reset voltage	DC 2...4 V
Reset time at reset voltage DC 2 V	1...2 s	
Protocol	Collective (with and without current limitation)	
Compatibility	See 'List of compatibility'	

Line separator	Line voltage:		
	• Nominal	DC 32 V (= V_{nom})	
	• Minimum	DC 12 V (= V_{min})	
	• Maximum	DC 33 V (= V_{max})	
	Voltage at which the line separator opens:		
	• Minimum	DC 7.5 V (= $V_{SO min}$)	
	• Maximum	DC 10.5 V (= $V_{SO max}$)	
	Permanent current when switches are closed	Max. 0.5 A (= $I_{C max}$)	
	Switching current (e.g., in the event of a short-circuit)	Max. 1 A (= $I_{S max}$)	
	Leakage current when switches are open	Max. 1 mA (= $I_{L max}$)	
Serial impedance when switches are closed	Max. 0.5 Ω (= $Z_{C max}$)		
External alarm indicators	Number of external alarm indicators that can be connected	2	
	Voltage	DC 6...17 V	
	Current	9...15 mA	
	Length of line	<ul style="list-style-type: none"> • Max. 30 m with unshielded cables (recommended) or if the shielding on the detector is connected to the positive pole for the external alarm indicator • Max. 5 m, if the shielding is connected to earth 	
	Flashing interval times on FDnet/C-NET detector line:		
	• Bright	15 ms	
	• Dark	1 s	
	Flashing interval times on collective detector line	Control panel-specific	
	Device characteristics	Number of sensors:	3
Connections	Detector line:		
	• Design	Socket strip	
	• Cable cross section	0.2...1.5 mm ²	
	External alarm indicators:		
	• Design	Socket strip	
	• Cable cross section	0.2...1.5 mm ²	

Ambient conditions	Operating temperature:	-35...+70 °C
	Storage temperature	-40...+75 °C
	Air humidity	≤95 % rel.
	Protection category (IEC 60529):	IP67
	Electromagnetic compatibility:	
	<ul style="list-style-type: none"> • 1 MHz...1 GHz 50 V/m • 1 GHz...2 GHz 30 V/m 	
Mechanical data	Dimensions (L x W x H)	135 x 135 x 77 mm
	Weight:	
	<ul style="list-style-type: none"> • Base for flame detector 0.25 kg • Flame detector 0.5 kg 	
	Material:	
	<ul style="list-style-type: none"> • Base for flame detector ABS/PC-Blend • Flame detector Aluminum casting 	
	Color	~RAL 9010 pure white
Standards	European standards	<ul style="list-style-type: none"> • EN 54-10 • EN 54-17

8.2 Dimensions

Base for flame detector FDB291

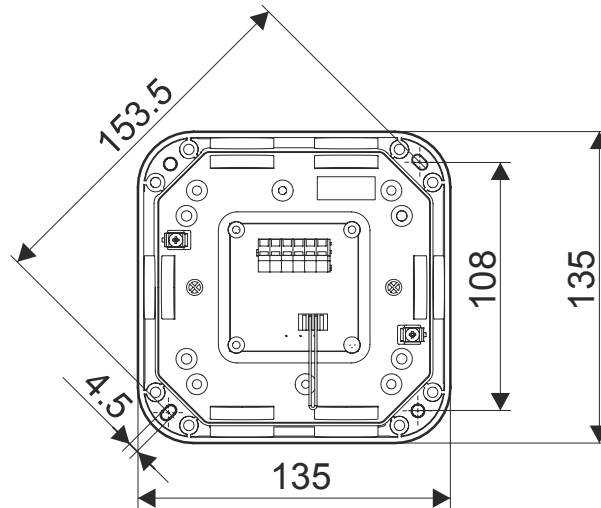

Base for flame detector FDB291 with flame detector FDF241 9
M20 x 1.5

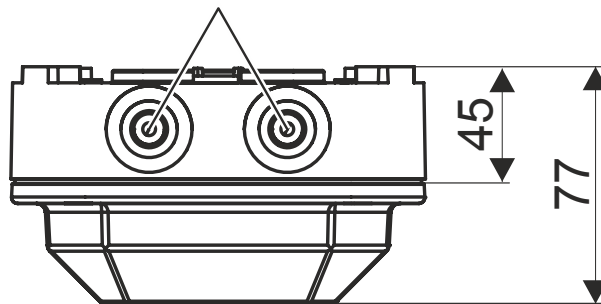

Mounting bracket MV1

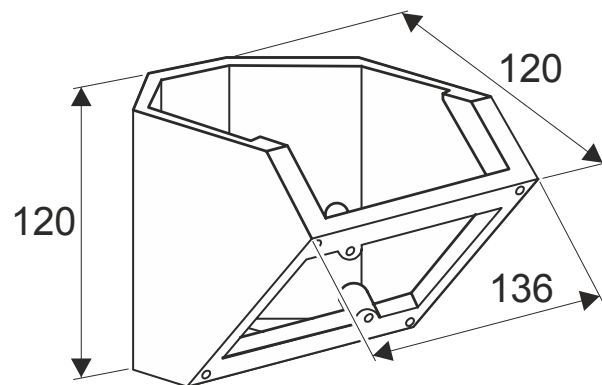

Ball and socket joint MWV1

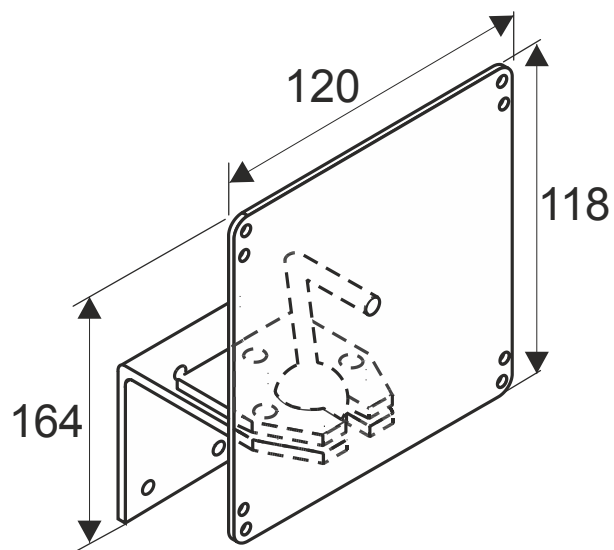

Rain hood DFZ1190

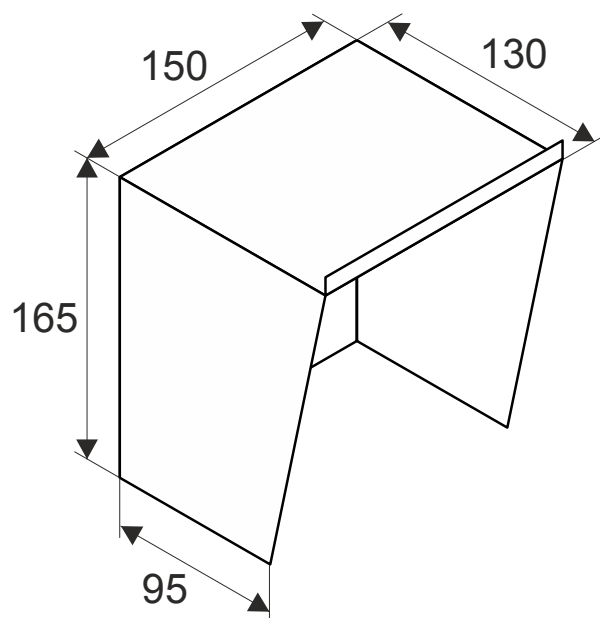

Rain hood FDFZ241

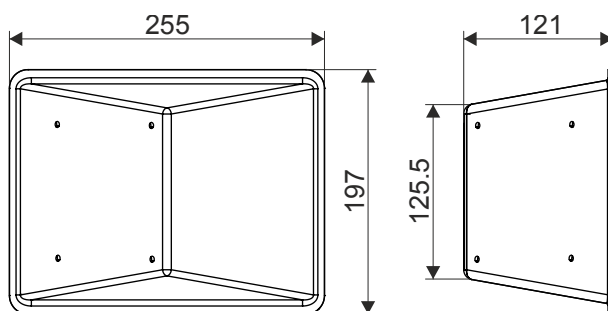

8.3 Environmental compatibility and disposal



This equipment is manufactured using materials and procedures which comply with current environmental protection standards as best as possible. More specifically, the following measures have been undertaken:

- Use of reusable materials
- Use of halogen-free plastics
- Electronic parts and synthetic materials can be separated

Larger plastic parts are labeled according to ISO 11469 and ISO 1043. The plastics can be separated and recycled on this basis.



Electronic parts and batteries must not be disposed of with domestic waste.

- Take electronic parts and batteries to local collection points or recycling centers.
- Contact local authorities for more information.
- Observe national requirements for disposing of electronic parts and batteries.

Index

A

Accessories

- Ball and socket joint..... 16, 25, 42
- Mounting bracket..... 16, 25, 42
- Rain hood..... 16, 25, 42
- Test lamp..... 26, 56

Aircraft hangar 31

Alarm

- Message to control panel..... 24

Alcohol fire..... 22

Approvals 59

Arrangement..... 28, 30

ASA..... 8

ASAt echnology 22

B

Ball and socket joint..... 16, 25, 42

Basic fire size..... 33

Bridging connector..... 19

C

CE marking..... 59

Class of detectors..... 37

Cleaning..... 57

Collective operation

- Switching over to collective operation..... 40

Compatibility 17

Connection 44

- Addressed detector line 45, 46
- Collective detector line..... 47, 48, 49

Connection cable..... 21

Connection diagram

- Addressed detector line with shielding..... 46
- Addressed detector line without shielding..... 45
- Collective detector line with shielding 48
- Collective detector line without shielding 47

Correction coefficient 33

- Detector sensitivity..... 33
- Directional sensitivity 34
- Fuel 34
- Vision angle 34

D

Danger level 24

Deceptive phenomenon..... 22, 31, 33, 36, 37

- Arc welding..... 31
- Halogen lamp 31

Hot objects 31

Solar radiation 31

Detection distance..... 32, 33, 35

Formula..... 33

Detector sensitivity 33, 37

Correction coefficient..... 33

Dimensions..... 62

Direct irradiation..... 29

Directional sensitivity 34

Correction coefficient..... 34

Disposal 64

Download center

URL..... 8

E

Electrical connection..... 44

End-of-line..... 47, 48

Environmental compatibility 64

Error

Message to control panel..... 24

EU directives 59

External alarm indicator..... 44, 45, 46, 60

F

False alarm..... 31

Fault 24, 58

Message to control panel..... 24

Fire size wanted 33

Formula

Detection distance 33

Mounting height 35

Freight forwarding hall..... 31

Fuel 34

Correction coefficient..... 34

G

Gas fire 16

I

Incorrect parameter

Message to control panel..... 24

Indirect irradiation..... 29

Infrared radiation 22, 29

Installation 40

Integration time 37

Intended use..... 5

Irradiation 29

L		
Line of sight.....	29	
Line separator	23, 60	
Liquid fire.....	16	
List of compatibility.....	7	
M		
Maintenance interval	56	
Mask	31, 36	
Message.....	24	
'Alarm'	24	
'Error'.....	24	
'Fault'.....	24	
'Incorrect parameter'	24	
Monitoring area.....	28, 29	
Monitoring redundancy	30	
Mounting.....	40	
Base for flame detector.....	42	
Flame detector.....	50, 54	
Mounting bracket	16, 25, 42	
Mounting height	32, 35	
Formula.....	35	
Mounting site.....	32	
O		
Order number	17	
P		
Parameter set.....	37, 38, 52, 53	
FDF241-9.....	38	
Set	52, 53	
Performance check	56	
Pyroelectric sensor.....	22	
R		
Rain hood	16, 25, 42	
Recycling.....	64	
Repair	58	
Resistance to deceptive phenomena.....	37, 38	
S		
Selftest	23	
Sensor.....	17, 20, 22	
Pyroelectric sensor	22	
Silicon photo diode	22	
Sensory	17, 22	
Silicon photo diode.....	22	
S-LINE.....	8	
Standards	61	
Switching over to collective operation	40	
T		
Test fire	57	
Test lamp.....	26, 56	
V		
Vision angle	34, 36	



Issued by
Siemens Switzerland Ltd
Building Technologies Division
International Headquarters
Gubelstrasse 22
CH-6301 Zug
+41 41-724 24 24
www.siemens.com/buildingtechnologies

© Siemens Switzerland Ltd, 2003
Technical specifications and availability subject to change without notice.